

PRODUCT DATA SHEET

STRICKLY BOARD MARKER SUPPORT



DESCRIPTION

Board label carriers are generally preferred products to be used inside the board. The piles of cables located inside the dashboard create confusion and confusion. Cable ties easily prevent this chaos with the help of label carriers it is passable. With this product, which is quite easy and convenient to use, the user's working efficiency can be increased by making the interior of the dashboard much more organized.

FEATURES

- Material : ABS Six-Piece, PS Cover + Double-Sided Tape
- Operating Temperature : -40 ° C --- +60 ° C
- Color : Black

MARKINGS



- It complies with RoHS standards.
- It complies with ISO 9001 standards.
- It complies with UL standards.
- It complies with CE standards.

PRODUCT DATA SHEET

STRICKLY BOARD MARKER SUPPORT

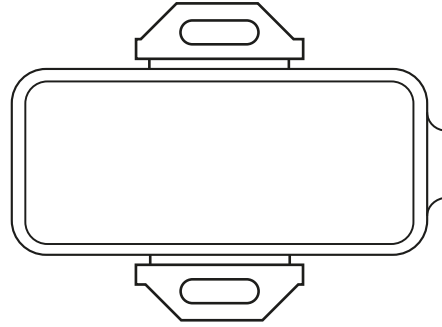

SECTIONS AND DIMENSIONS

PRODUCT CODE	COLOUR	DIMENSIONS		LABEL WIDTH (mm)	LABEL LENGTH (mm)
		A	B		
GPET - 1	Black	30	17	27.5	14.4
GPET - 2	Black	50	17	49	15
GPET - 1	Black	75	17	72	15